



# PRODUCT SELECTION GUIDE

**YUEQING KASHENG ELECTRIC CO.,LTD**



## Application

KiC60N KiC65N series circuit breaker belongs to the advanced level instead of the old generation of KC60N. They have protective functions as shortage and overloading, and are caused in lighting distribution system in industry, commerce and dwelling, and protect fractional electric motors. And they also have many merits of high protective grade (up to Ip20), high breaking capacity, good reliability of sensitive action, convenient multi-pole assorting, long using life etc. They are mainly adapted to the circuit of AC50Hz, 230V in single pole, 400V in double, three on four poles for protecting overload and shortage. Meanwhile, they are also used lighting on or off the electric apparatus and lighting circuit under the normal condition.

## Specification

- Character: B C D
- Standard: IEC898; IEC847-2
- Rated current(A): 1,2,3,4,5,6,10,16,20,25,32,40,50,63A
- Pole(S): 1,2,3,4
- Rated voltage(V): 230/340; 130V; 380/415V; 400V
- Breaking capacity: 3000, 6000, 10000, 20000

## Characteristic curve

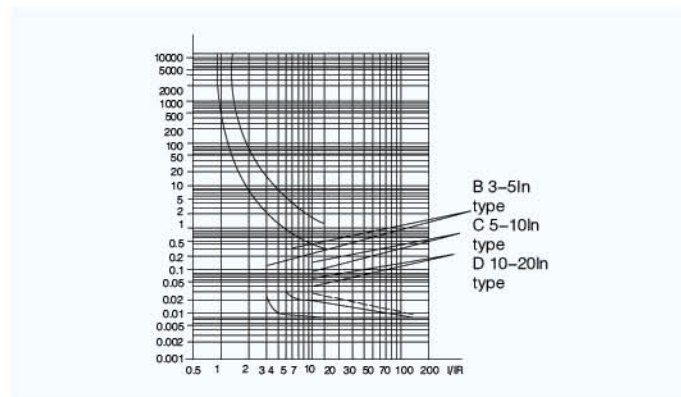

## Overall & Installation Dimensions

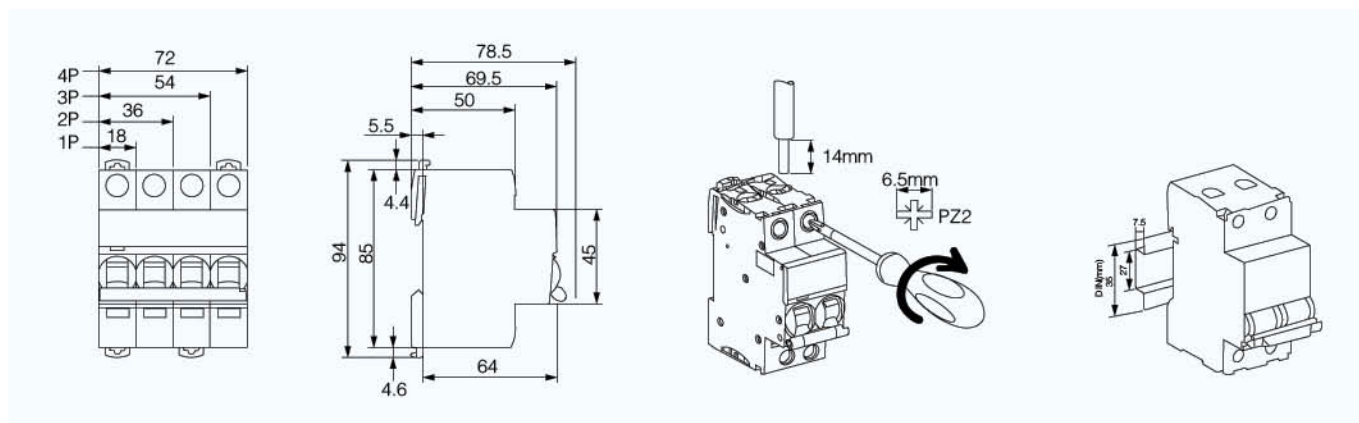



## Construction and Feature

- Capable of switch electric circuit with load
- Capable of releasing stored energy operation
- Adaptable to padlock device
- Contact position indication

- Highlighted of high making and capacity
- High short-circuit current withstand capacity
- Used as main switch for household and similar installation

## Technical Data

Pole No	1,2,3,4
Rated current(A)	1,2,3,4,5,6,10,16,20,25,32,40,50,63
Rated voltage	230/400V AC
Rated frequency	50/60hz
Rated short-circuit making capacity	10000A
Rated withstand current	1000A within 1 sec
Electro-mechanical endurance	10000cycles
Connection terminal	Screw terminal、Pillar terminal with clamp
Installation	Panel mounting

## Overall&Installation Dimensions

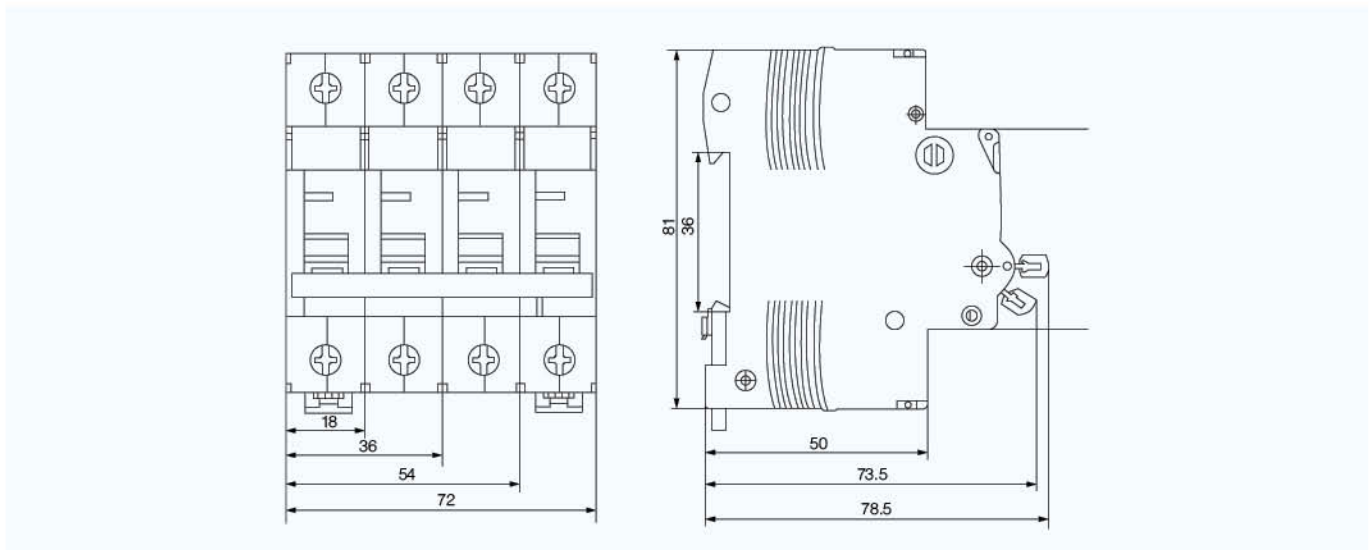



## Construction and Feature

Protection against both overload and short circuit  
 High short-circuit capacity  
 Contact position indication

Applicable terminal and pin/fork type busbar connection  
 Easy mounting onto 35mm DIN rail

## Technical Data

Pole No	1, 1P+N, 2, 3, 3P+N, 4
Rated voltage	AC 230/400V
Rated current(A)	1, 2, 3, 4, 6, 10, 13, 16, 20, 25, 32, 40, 50, 63
Tripping curve	B, C, D
Ultimate short-circuit capacity(Icu)	6KA
Rated frequency	50/60Hz
Energy limiting class	3
Rated impulse withstand voltage	6.2KV
Electro-mechanical endurance	6000
Connection terminal	Screw terminal, Pillar terminal with clamp
Connection capacity	Rigid conductor up to 25mm <sup>2</sup>
Fastening torque	2.0Nm
Installation	On symmetrical DIN rail 35 mm, Panel mounting
Terminal Connection Height	19mm

## Overall & Installation Dimensions

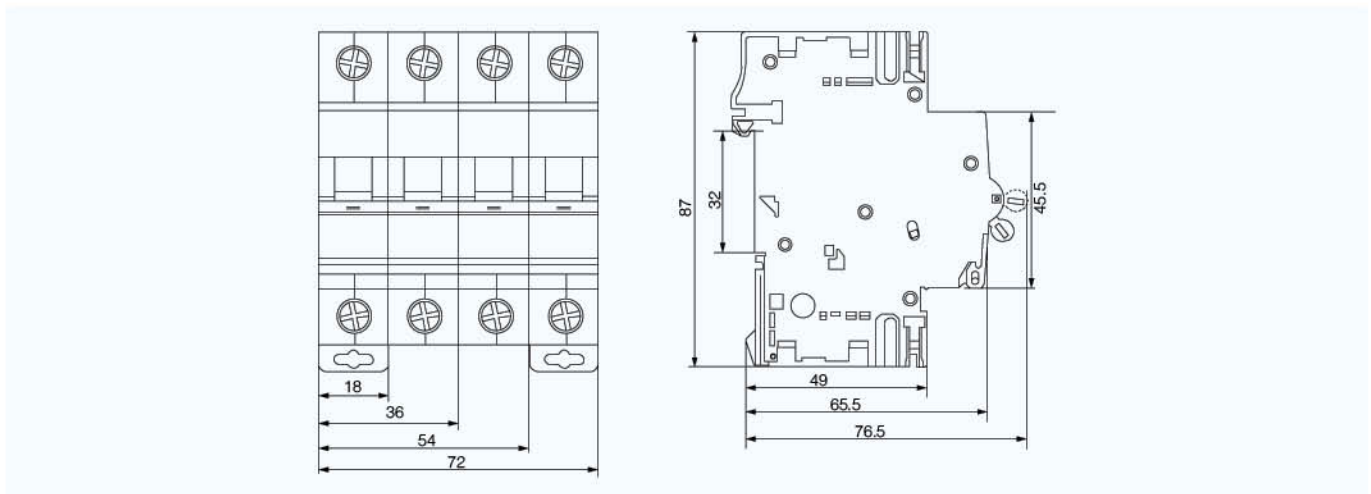



# MCB



## Application

KC60N KC65N series circuit breaker belongs to the advanced level of the nineties in the world instead of the old generation of KC45N. They have protective functions as shortage and overloading, and are caused in lighting distribution system in industry, commerce and dwelling, and protect fractional electric motors. And they also have many merits of high protective grade (up to Ip20), high breaking capacity, good reliability of sensitive action, convenient multi-pole assorting, long using life etc. They are mainly adapted to the circuit of AC50Hz, 230V in single pole, 400V in double, three on four poles for protecting overload and shortage. Meanwhile, they are also used lighting on or off the electric apparatus and lighting circuit under the normal condition.

## Specification

Character: B C D

Standard: IEC898 IEC847-2

Rated current (A): 1, 2, 3, 4, 5, 6, 10, 16, 20, 25, 32, 40, 50, 63A

Pole(S): 1, 2, 3, 4

Rated voltage (V): 230/340; 130V; 380/415V; 400V

Breaking capacity: 3000, 6000, 10000, 20000

## Overall & Installation Dimensions

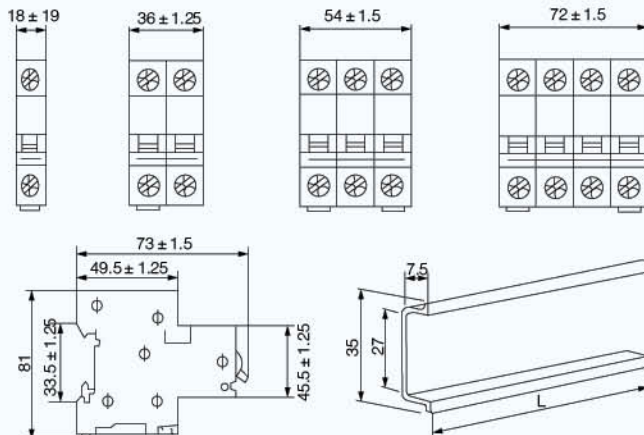

## Characteristic curve

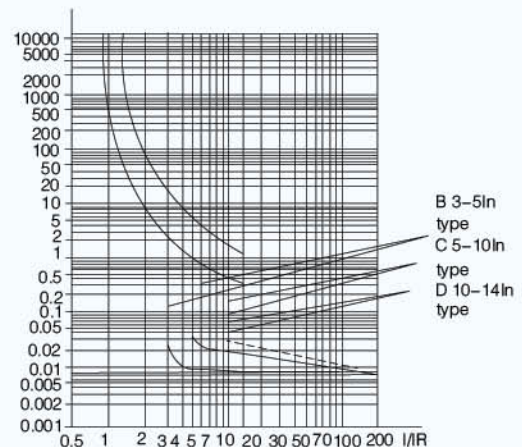



## Application

For protection against risk of fire due to live to earth fault where fault current is insufficient to cause over-current protection device to operate.

For protection against risk of shock from indirect contact with equipment suffering a live to earth fault.

For protection against shock in potentially hazardous environment.

As supplementary protection against shock from directly touching live parts.

Note : an RCCB must not be used as the sole means of protection against touching live parts.

## Specifications

Rated working voltage: 240/415V

Rated frequency: 50/60Hz

Rated working current: 16, 20, 25, 32, 40, 50, 63A

Rated residual operating current: 0.03, 0.1, 0.3A

Rated residual un-operating current: 0.015, 0.05, 0.15A

Sensibility: AC Type

Maximum operating time:  $I \Delta n \quad t \leq 0.1s$ ,  $51 \Delta n \quad t \leq 0.04$

## Dimensions(mm)

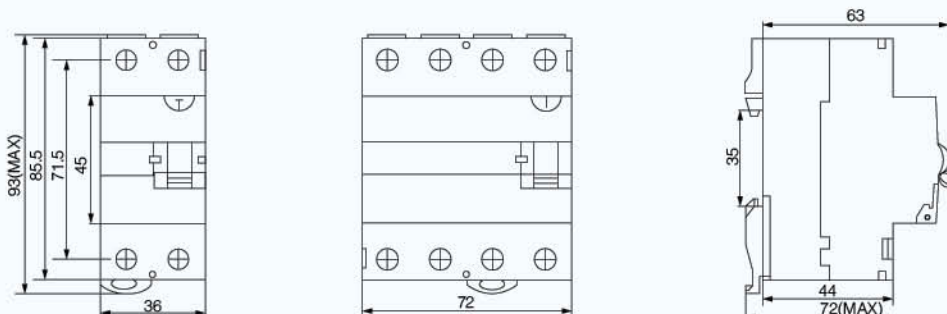



## Application

For protection against risk of fire due to live to earth fault where fault current is insufficient to cause over-current protection device to operate.

For protection against risk of shock from indirect contact with equipment suffering a live to earth fault.

For protection against shock in potentially hazardous environment.

As supplementary protection against shock from directly touching live parts.

Note : an RCCB must not be used as the sole means of protection against touching live parts.

## Specifications

Rated working voltage: 240/415V

Rated frequency: 50/60Hz

Rated working current: 16, 20, 25, 32, 40, 50, 63A

Rated residual operating current: 0.03, 0.1, 0.3A

Rated residual un-operating current: 0.015, 0.05, 0.15A

Sensibility: AC Type

Maximum operating time:  $I \Delta n \quad t \leq 0.1s$ ,  $51 \Delta n \quad t \leq 0.04$

## Dimensions(mm)

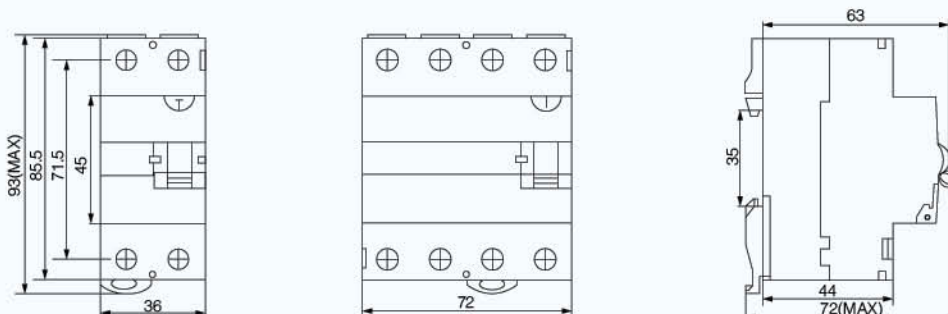



## Application

The item is in comply with standard of IEC61008-1, applying to the circuit of AC 50/60Hz, 230V single phase, 400V three phases or below it for industrial and mining enterprise, trade building, commerce and family. It is mainly used for preventing electric fire and personal casual accident caused by personal electric shock or leakage of electrified wire net, this is a current operated, fast leakage protector of pure electromagnetic type, which can break off fault circuit rapidly in order to avoid occurrence of accident.

The item is precise in structure, less elements, without auxiliary power and high working reliability.

The function of the switch won't be influenced by ambient temperature and lightning. The mutual inductor of the item is used to test vector differential value of passing current, and produces a relevant output power and add it to the tripper in secondary winding, if the current of vector differential value of protected circuit of personal electric shock is up to or over leakage operating current, the tripper will act and cut off so that the item will take effect of protection.

## Specifications

	Standard		IEC/NE61008
	Mode		Electro-magnetic type, electronic type
	Type(wave form of the earth leakage sensed)		A, AC
Electrical features	Rated current I <sub>n</sub>	A	16,25,32,40,63
	Poles	P	2,4
	Rated voltage U <sub>e</sub>	V	AC 240/415
	Rated sensitivity I <sub>Δn</sub>	A	0.01,0.03,0.1,0.3,0.5
	Insulation voltage U <sub>i</sub>	V	500
	Rated residual making and breaking capacity I <sub>Δn</sub>	A	630
	Short-circuit current I <sub>Δc</sub>	A	4500,6000
	SCPD fuse	A	6000
	Rated frequency	Hz	50/60
	Pollution degree		2
Mechanical features	Electrical life	t	6000
	Mechanical life	t	10000
	Protection degree		IP20
	Ambient temperature (with daily average ≤ 35°C)	°C	-25 ~ +40
	Storage temperature	°C	-25 ~ +70
Installation	Terminal connection type		Cable/U-type busbar/pin-type busbar
	Terminal size top/bottom for cable	mm <sup>2</sup>	25
		AWG	18-3
	Terminal size top/bottom for busbar	mm <sup>2</sup>	25
		AWG	18-3
	Tightening torque	N*m	2.5
		ln-lbs.	22
Mounting		On DIN rail EN 6071 5(35mm) by means of fast clip device	
Connection		From top and bottom	



# RCCB



## Application

For protection against risk of fire due to live to earth fault where fault current is insufficient to cause over-current protection device to operate.

For protection against risk of shock from indirect contact with equipment suffering a live to earth fault.

For protection against shock in potentially hazardous environment.

As supplementary protection against shock from directly touching live parts.

Note : an RCCB must not be used as the sole means of protection against touching live parts.

## Dimensions(mm)

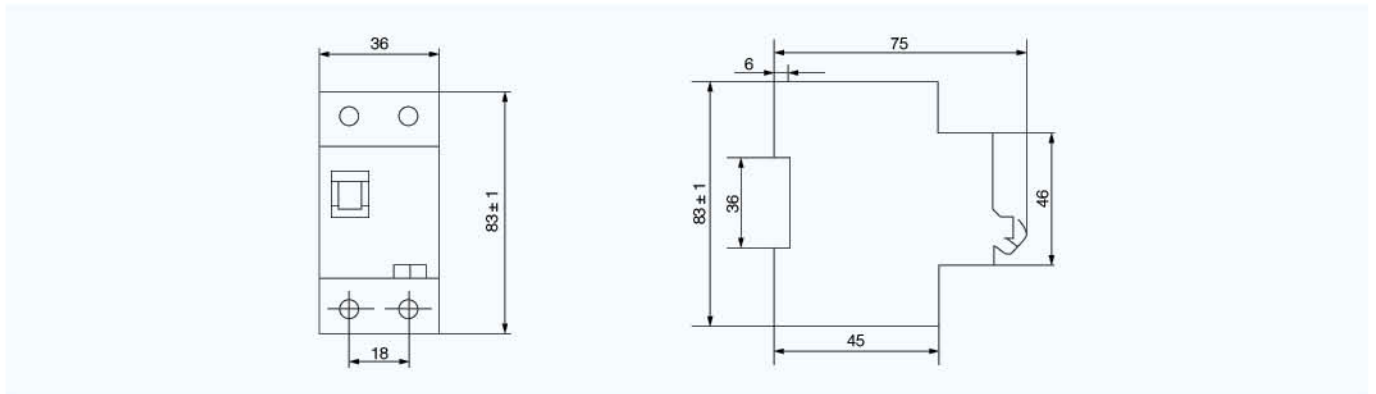

## Overall and mounting dimensions





## Application

The item is in comply with standard of IEC61008-1, applying to the circuit of AC 50/60Hz, 230V single phase, 400V three phases or below it for industrial and mining enterprise, trade building, commerce and family. It is mainly used for preventing electric fire and personal casual accident caused by personal electric shock or leakage of electrified wire net, this is a current operated, fast leakage protector of pure electromagnetic type, which can break off fault circuit rapidly in order to avoid occurrence of accident. The item is precise in structure, less elements, without auxiliary power and high working reliability.

The function of the switch won't be influenced by ambient temperature and lightning. The mutual inductor of the item is used to test vector differential value of passing current, and produces a relevant output power and add it to the tripper in secondary winding, if the current of vector differential value of protected circuit of personal electric shock is up to or over leakage operating current, the tripper will act and cut off so that the item will take effect of protection.

## Specification

Number of Poles: 2P,4P

Rated Current (A): 16,20,25,32,40,50,63

Rated Residual Operating Current ( $I_{\Delta n}$ )(mA): 30,100,300,500

Rated Residual Non-Operating Current( $I_{\Delta n}$ )(mA):  $\leq 0.5 I_{\Delta n}$

Rated Voltage (V): AC230/400

Residual Current Off-time:  $\leq 0.1S$

Short Circuit Capacity ( $I_{cu}$ ): 3000A

Endurance:  $\geq 4000$

Protection Degree: IP20

## Dimensions(mm)

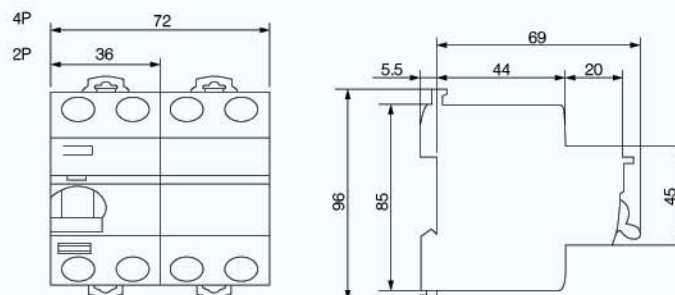



## Application

KLC1-DN series AC contactor is suitable for frequency 50/60Hz, rated insulation voltage up to 1000V, rated operation current 9 ~ 150A under AC-3 duty. It is mainly used for making/breaking electric circuits at a long distance & for frequent starting/stopping & controlling AC Motors. It is used in combination with thermal relay to compose a magnetic motor starter. The products comply with IEC60947-4-1 standard.

## Specification

Type	KLC1							
	DN09	DN12	DN18	DN25	DN32	DN38	DN40	
Rated working current Ie (A) AC-3 Ue≤440V	9	12	18	25	32	38	40	
Rated hear current Ith (A)	25	25	32	40	50	50	60	
Rated insulation voltage Ui (V)	690	690	690	690	690	690	1000	
Rated operating voltage Ue (V) Max	690	690	690	690	690	690	1000	
Rated operational power in AC-3 Pe (KW)	220/230V	2.2	3	4	5.5	7.5	9	11
	380/400V	4	5.5	7.5	11	15	18.5	18.5
	415/440V	4	5.5	9	11	15	18.5	22
	500V	5.5	7.5	10	15	18.5	18.5	22
	660/690V	5.5	7.5	10	15	18.5	18.5	30
Rated operational power in AC-4 Pe (KW)	220/230V	1.5	1.5	2.2	3	4	4	4
	380/400V	2.2	3.7	4	5.5	7.5	7.5	9
	415/440V	2.2	3	3.7	5.5	7.5	7.5	9/11
	500V	3	4	5.5	7.5	9	9	11
	660/690V	4	5.5	7.5	10	11	11	15
Frequency of operation (l/h)	1200	1200	1200	1200	1000	1000	1000	
Electrical endurance ( × 10 <sup>4</sup> )	AC-3	100	100	100	100	80	80	80
	AC-4	20	20	20	20	20	20	15
Mechanical endurance ( × 10 <sup>6</sup> )	15	15	15	15	15	15	6	
Operating voltage range of coil	Close voltage:(0.85 ~ 1.1)Us			Open voltage:(20% ~ 75%)Us				
Power consumption of coil (VA)	Attracting	7	7	7	7	7	7	20
	Starting	70	70	70	70	70	70	200
Rated insulation voltage of auxiliary contacts (V)	690	690	690	690	690	690	690	
Conventional thermal current of auxiliary contacts (A)	10	10	10	10	10	10	10	
Auxiliary contacts specification	AC-15:360VA			DC-13:33W				



## Outline And Mounting Dimension:

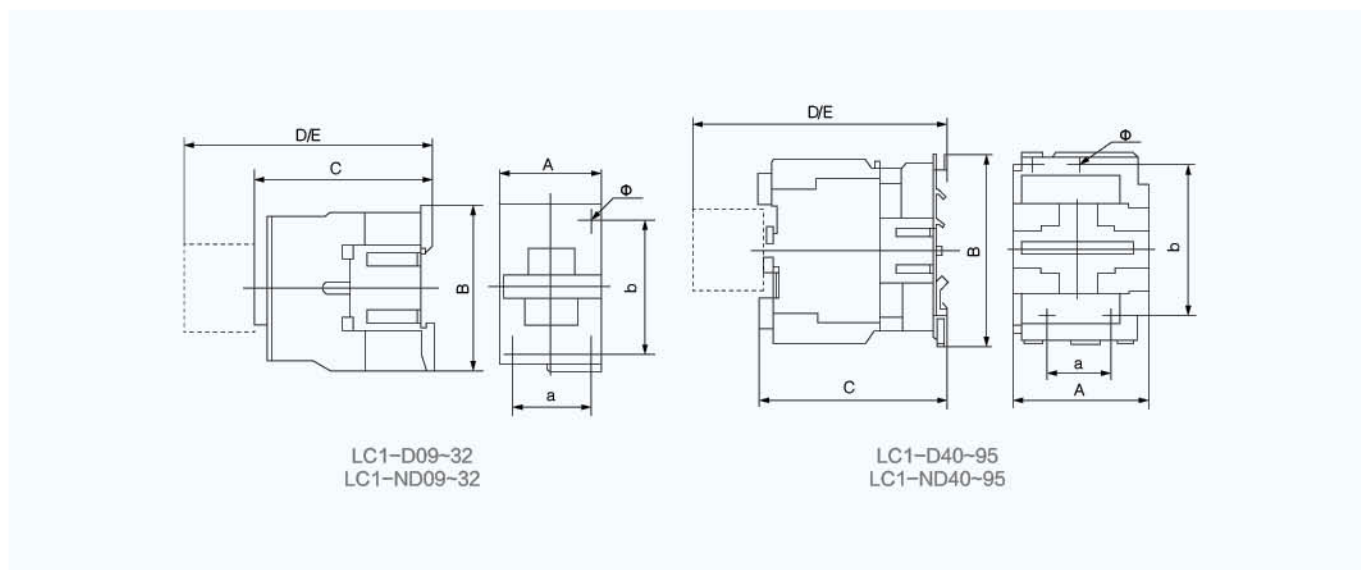

Type	A	B	C	D	E	a	b	φ
LC1-D09-12	47	76	82	113	133	34/35	50/60	4.5
LC1-D18	47	76	87	118	138	34/35	50/60	4.5
LC1-D25	57	86	95	126	146	40	48	4.5
LC1-D32	57	86	100	131	151	40	48	4.5
LC1-D40-65	77	129	116	145	165	40	100/110	6.5
LC1-D80-95	87	129	127	175	195	40	100/110	6.5





## Application

KLC1-D series AC Contactor is suitable for using in the circuits up to the rated voltage 660VAC 50Hz or 60Hz, rated current up to 620A, for making, breaking, frequently starting & controlling the AC motor. Combined with the auxiliary contact block, timer delay & machine-interlocking device etc, it becomes the delay contactor, mechanical interlocking contactor, star-delta starter.

With the thermal relay, it is combined into the electromagnetic starter. The product conforms to IEC60947-4-1 standard.

## Specification

Type		KLC1									
		D09	D12	D18	D25	D32	D40	D50	D65	D80	D95
Rated working current(A)	AC3	9	12	18	25	32	40	50	65	80	95
	AC4	3.5	5	7.7	8.5	12	18.5	24	28	37	44
Standard power ratings of 3-phase motors 50/60Hz in category AC-3	220/230V	2.2	3	4	5.5	7.5	11	15	18.5	22	25
	380/400V	4	5.5	7.5	11	15	18.5	22	30	37	45
	415V	4	5.5	9	11	15	22	25	37	45	45
	500V	5.5	7.5	10	15	18.5	22	30	37	55	55
	660/690V	5.5	7.5	10	15	18.5	30	33	37	45	55
Rated heat current (A)		20	20	32	40	50	60	80	80	125	125
Electrical life	AC3 ( × 10 <sup>4</sup> )	100	100	100	100	80	80	60	60	60	60
	AC4 ( × 10 <sup>4</sup> )	20	20	20	20	20	15	15	15	10	10
Mechanical life ( × 10 <sup>4</sup> )		1000	1000	1000	1000	800	800	800	800	600	600
Number of the contacts		3P+NO 3P+NC					3P+NC+NO				

## Outline and mounting dimension

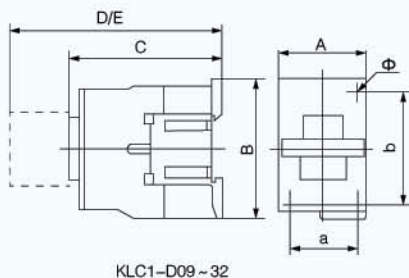

Type	A	B	C	D
KLC1-D09-12	47	76	82	113
KLC1-D18	47	76	87	118
KLC1-D25	57	86	95	126
KLC1-D32	57	86	100	131
KLC1-D40-65	77	129	116	145
KLC1-D80-95	87	129	127	175
Type	E	a	b	Φ
KLC1-D09-12	133	34/35	50/60	4.5
KLC1-D18	138	34/35	50/60	4.5
KLC1-D25	146	40	48	4.5
KLC1-D32	151	40	48	4.5
KLC1-D40-65	165	40	100/110	6.5
KLC1-D80-95	195	40	100/110	6.5

# DOL ELECTROMAGNETIC STARTER



## Application

KLE1-DN magnetic starter is mainly applied to circuit of AC 50 or 60Hz, voltage up 550V for far distance making and breaking circuit and frequent starting and controlling motor. It has the features of small volume, light weight, low power consumption, high efficiency, safe and reliable performance etc.

## Specifications

Maximum power AC3 duty(KW)						Rated current (A)	Type of enclosure	Code Number		Suitable Thermal Relay(A)
220V 230V	220V 230V	415V	440V	500V	660V			LL (long life)	NL(3) (normal life)	
2.2	4	4	4	5.5	690V	9	IP42 IP65	KLE1 D0.94... KLE1 D093...	- -	KLR2 D1312 KLR2 D1314
3	5.5	5.5	5.5	7.5	5.5	12	IP42 IP65	KLE1 D124... KLE1 D123...	KLE1 D0.94... KLE1 D093...	KLR2 D1316
4	7.5	9	9	10	7.5	18	IP42 IP65	KLE1 D188... KLE1 D185...	KLE1 D124... KLE1 D123...	KLR2 D1321
5.5	11	11	11	15	10	25	IP42 IP65	KLE1 D258... KLE1 D255...	KLE1 D188... KLE1 D185...	KLR2 D1322 KLR2 D2353
7.5	15	15	15	18.5	15	32	IP55	KLE1 D325...	KLE1 D255...	KLR2 D2355
11	18.5	22	22	22	18.5	40	IP55	KLE1 D405...	KLE1 D325...	KLR2 D3353 KLR2 D3355
15	22	25	30	30	30	50	IP55	KLE1 D505...	KLE1 D405...	KLR2 D3357 KLR2 D3359
18.5	30	37	37	37	33	65	IP55	KLE1 D655...	KLE1 D505...	KLR2 D3361
22	37	45	45	55	37 45	80	IP55	KLE1 D805...	KLE1 D655...	KLR2 D3363 KLR2 D3365
25	45	45	45	55	45	95	IP55	KLE1 D955...	KLE1 D805...	KLR2 D3365

Enclosure	KLE1DN09 and DN12	Double insulated,protected to IP 429(3)or to IP 659(4)
	KLE1DN18 and DN25	Double insulated,protected to IP 427(3)or to IP557(4)
	KLE1DN32...DN25	Metal,IP55 to IP559
Control(2 pushbuttons mounted on enclosure cover)	KLE1DN09...DN95	1 green Start button"1" 1 red Stop/Reset button"0"
Connections	KLE1DN09...DN95	Pre-wired power and control circuit connection
Standard control circuit volatges		
Volts	24 42 110 220/230 230 240 380/400 400 415 440	
50/60Hz	B7 D7 F7 M7 P7 U7 Q7 V7 N7 R7	